

# \*TB 9-6625-1935-24

DEPARTMENT OF THE ARMY TECHNICAL BULLETIN

## CALIBRATION PROCEDURE FOR POWER METER, ME-441/U (AGILENT, MODEL 432A) AND AGILENT, MODEL 432B

Headquarters, Department of the Army, Washington, D. C.  
28 June 2007

*Distribution Statement A: Approved for public release; distribution is unlimited.*

### REPORTING OF ERRORS AND RECOMMENDING IMPROVEMENTS

You can improve this manual. If you find any mistakes or if you know of a way to improve these procedures, please let us know. Mail your letter or DA Form 2028 (Recommended Changes to Publications and Blank Forms) directly to Commander, US Army Aviation and Missile Command, ATTN: AMSAM-MMC-MA-NP, Redstone Arsenal, AL 35898-5000. A reply will be furnished to you. You may also provide DA Form 2028 information to AMCOM via e-mail, fax, or the World Wide Web. Our FAX number is: DSN 788-6546 or Commercial 256-842-6546. Our e-mail address is: [2028@redstone.army.mil](mailto:2028@redstone.army.mil). Instructions for sending an electronic 2028 may be found at the back of this manual. For the World Wide Web, use: <https://amcom2028.redstone.army.mil>.

SECTION		Paragraph	Page
	I. IDENTIFICATION AND DESCRIPTION		
	Test instrument identification.....	1	2
	Forms, records, and reports .....	2	2
	Calibration description .....	3	2
	II. EQUIPMENT REQUIREMENTS		
	Equipment required .....	4	3
	Accessories required.....	5	3
	III. CALIBRATION PROCESS		
	Preliminary instructions.....	6	3
	Equipment setup .....	7	4
	Meter accuracy test .....	8	4
	Calibration factor test .....	9	7
	Meter linearity test .....	10	8
	Zero carryover test.....	11	8
	Final procedure.....	12	10

\*This bulletin supersedes TB 9-6625-1935-35, dated 25 March 1995.

SECTION		Paragraph	Page
	IV. CALIBRATION PROCESS WITHOUT POWER METER CALIBRATOR		
	Preliminary instructions.....	13	11
	Equipment setup .....	14	11
	Meter accuracy and zero carryover test.....	15	12
	Recorder output test.....	16	13
	Calibration factor test .....	17	13
	Final procedure.....	18	14

**SECTION I  
IDENTIFICATION AND DESCRIPTION**

**1. Test Instrument Identification.** This bulletin provides instructions for the calibration of Power Meter, ME-441/U (Agilent, Model 432A) and Agilent, Model 432B. The manufacturers’ manuals were used as the prime data source in compiling these instructions. The equipment being calibrated will be referred to as the TI (test instrument) throughout this bulletin.

**a. Model Variations.** Some models do not contain OPERATE/CALIBRATE switch A2S1 or variable resistor A2R86. Model 432A is identical to ME-441/U. Some models have digital indication.

**b. Time and Technique.** The time required for this calibration is approximately 1 hour, using the dc and low frequency technique.

**2. Forms, Records, and Reports**

**a.** Forms, records, and reports required for calibration personnel at all levels are prescribed by TB 750-25.

**b.** Adjustments to be reported are designated (R) at the end of the sentence in which they appear. When adjustments are in tables, the (R) follows the designated adjustment. Report only those adjustments made and designated with (R).

**3. Calibration Description.** TI parameters and performance specifications which pertain to this calibration are listed in table 1.

Table 1. Calibration Description

Test instrument parameters	Performance specifications
Power	Range: 10 $\mu$ W to 10 mW FS Accuracy: $\pm 1\%$ on all ranges (0 to +55 °C for model 432A (ME-441/U)) $\pm 1\%$ on 10 $\mu$ W range and $\pm 0.5\%$ on 100 $\mu$ W, 1 and 10 mW ranges for model 432B (20 to 30 °C)
Calibration factor	Range: 88 to 100% in 1% steps Accuracy: $\pm 1\%$ of FS
Recorder output	Range: 1 V Accuracy: $\pm 0.5\%$ of FS
Zero carryover	<0.5% of FS when zeroed on most sensitive range

**SECTION II  
EQUIPMENT REQUIREMENTS**

**4. Equipment Required.** Table 2 identifies the specific equipment to be used in this calibration procedure. This equipment is issued with Secondary Transfer Calibration Standards Set AN/GSM-287 or AN/GSM-705. Alternate items may be used by the calibrating activity. The items selected must be verified to perform satisfactorily prior to use and must bear evidence of current calibration. The equipment must meet or exceed the minimum use specifications listed in table 2. The accuracies listed in table 2 provide a four-to-one ratio between the standard and TI. Where the four-to-one ratio cannot be met, the actual accuracy of the equipment selected is shown in parenthesis.

**5. Accessories Required.** The accessories required for this calibration are common usage accessories, issued as indicated in paragraph 4 above, and are not listed in this calibration procedure.

Table 2. Minimum Specifications of Equipment Required

Common name	Minimum use specifications	Manufacturer and model (part number)
MULTIMETER	Range: -0.0004 to 1.01 V dc Accuracy: ±0.01%	Fluke, Model 8840A/AF05 (AN/GSM-64D)
POWER METER CALIBRATOR	Range: 0 to 10 mW Accuracy: <u>Model 432A:</u> ±0.25% (±0.5% on .01 and .03 mW ranges)  <u>Models 432B:</u> ±0.125% 100 µW, 1 and 10 mW ranges and ±0.25% 10 µW range (±0.2% 100 µW, 1 and 10 mW range and ±0.5% 10 µW range)	Hewlett-Packard, Model 8477A (8477A)
THERMISTOR MOUNT (RF BOLOMOTER)	Range: 0 to 10 mW Accuracy: ±5%	Hewlett-Packard, Model 478A (9975991)

**SECTION III  
CALIBRATION PROCESS**

**6. Preliminary Instructions**

**a.** The instructions outlined in paragraphs 6 and 7 are preparatory to the calibration process. Personnel should become familiar with the entire bulletin before beginning the calibration.

**b.** Items of equipment used in this procedure are referenced within the text by common name as listed in table 2.

**c.** Unless otherwise specified, verify the result of each test and, whenever the test requirement is not met, take corrective action before continuing the calibration. Adjustments required to calibrate the TI are included in this procedure. Additional maintenance information is contained in the manufacturers' manuals for this TI.

**d.** Unless otherwise specified, all controls and control settings refer to the TI.

## 7. Equipment Setup

### WARNING

HIGH VOLTAGE is used or exposed during the performance of this calibration. DEATH ON CONTACT may result if personnel fail to observe safety precautions. REDUCE OUTPUT(S) to minimum after each step within the performance check where applicable.

### NOTE

The following procedures are oriented to model 432A (ME-441/U) power meter. The technique for calibrating model 432B is the same with the following exceptions: Model 432B has only four range switch settings: 10 and 100  $\mu$ W and 1 and 10 mW. Omit checks for .03 and .3 mW ranges when calibrating model 432B.

- a. If necessary, mechanically zero model 432A (ME-441/U) meter as follows:

(1) Rotate mechanical adjustment screw clockwise until pointer is to left of **0** and moving up scale toward **0**. Stop when pointer is over **0** mark. If pointer overshoots, repeat the process.

(2) With pointer over **0**, turn adjustment screw approximately three degrees counterclockwise to free meter movement. If pointer moves off **0**, repeat adjustment.

- b. Connect TI to a 115 V ac source.

## 8. Meter Accuracy Test

### a. Performance Check

- (1) Position power meter calibrator controls as listed in (a) through (d) below:

- (a) **LINE** switch to **OFF**.
- (b) **FUNCTION** switch to **200  $\Omega$** .
- (c) **POWER** switch to **.01 mW**.
- (d) **ZERO/TEST** switch to **ZERO**.

- (2) Position TI controls as listed in (a) through (c) below:

- (a) **MOUNT RESISTANCE** switch to **200  $\Omega$** .
- (b) **RANGE** switch to **.01 mW (10  $\mu$ W for model 432B)**.
- (c) **CALIBRATION FACTOR** switch to **100 %**.

(3) If applicable, set OPERATE/CALIBRATE SWITCH A2S1 (fig. 1) to **CALIBRATE**.

(4) Connect equipment as shown in figure 2. Energize appropriate equipment and allow 10 minutes for equipment to warm-up and stabilize.

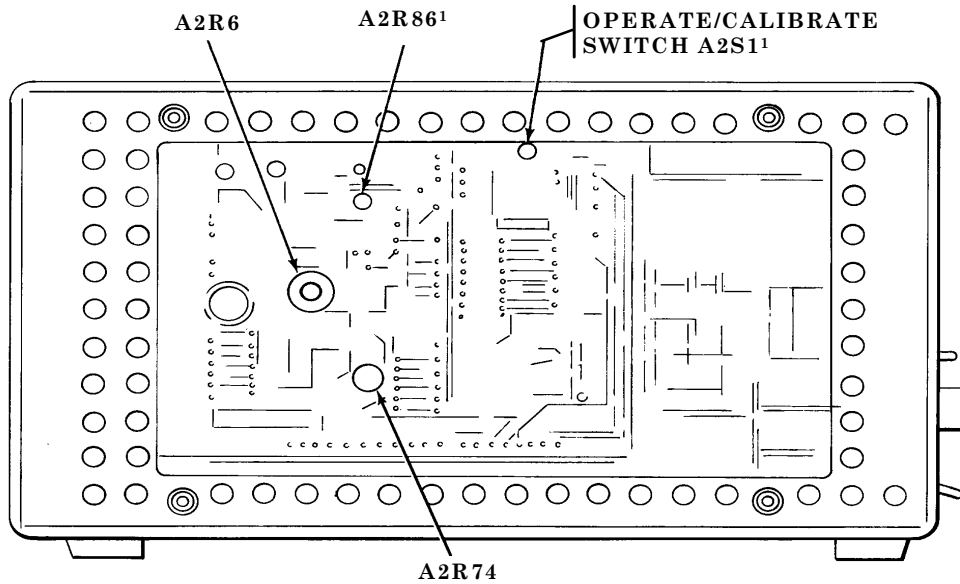

¹NOT ON ALL 432A MODELS

Figure 1. Test instrument - left side view.

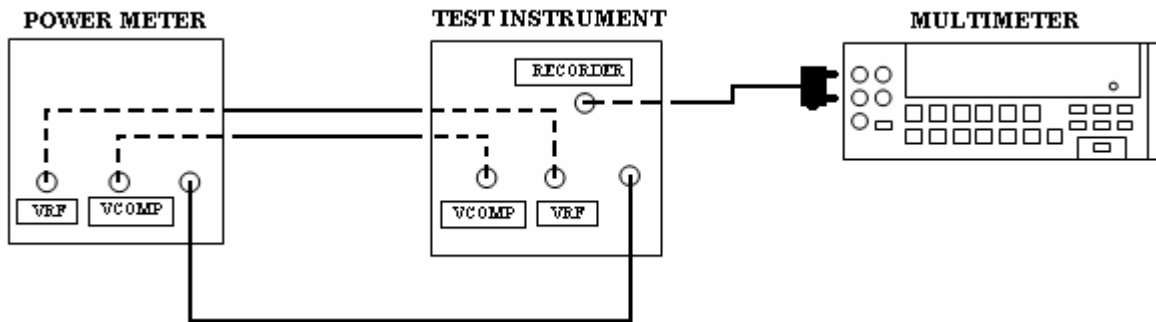

Figure 2. Meter accuracy test equipment setup.

(5) Adjust power meter calibrator **ZERO** control for an indication between -2 and +2 mV dc on multimeter

(6) Set power meter calibrator **ZERO/TEST** switch to **TEST**. Multimeter will indicate between 0.990 and 1.010 V dc and TI meter will indicate between 9.9 and 10.1  $\mu$ W.

(7) Set switches on TI and power meter calibrator to positions listed in table 3. If multimeter or TI does not indicate within limits specified for each switch position, perform **b** below.

Table 3. Meter Accuracy Test

Test instrument RANGE (mW) switch settings	Power meter calibrator POWER (mW) switch settings	Test instrument indications (mW)				Multimeter indications (V)			
		Model 432A		Model 432B		Model 432A		Model 432B	
		Min	Max	Min	Max	Min	Max	Min	Max
<b>.03</b> <sup>1</sup>	<b>.03</b>	0.0297	0.0303	---	---	0.9388	0.9588	---	---
<b>.1</b> (100 μW)	<b>.1</b>	0.099	0.101	0.0995	0.1005	0.990	1.010	0.995	1.005
<b>.3</b> <sup>1</sup>	<b>.3</b>	0.297	0.303	---	---	0.9388	0.9588	---	---
<b>1</b>	<b>1</b>	0.99	1.01	0.995	1.005	0.990	1.010	0.995	1.005
<b>3</b> <sup>1</sup>	<b>3</b>	2.97	3.03	---	---	0.9388	0.9588	---	---
<b>10</b>	<b>10</b>	9.9	10.1	9.95	10.05	0.990	1.010	0.995	1.005

<sup>1</sup>Omit these positions for model 432B.

**b. Adjustments**

- (1) Set power meter calibrator **ZERO/TEST** switch to **ZERO**.
- (2) Set TI **RANGE** switch to **1 mW**.
- (3) Set power meter calibrator **POWER** switch to **1 mW**.
- (4) Adjust power meter calibrator **ZERO** control for multimeter indication of ±1 mV dc.
- (5) Set power meter calibrator **ZERO/TEST** switch to **TEST**.
- (6) Adjust A2R6 (fig. 1) for TI meter indication between 0.99 and 1.01 mW (0.995 and 1.005 mW for model 432B) (R).
- (7) Adjust A2R74 (fig. 1) for multimeter indication between 0.999 and 1.001 V dc (R).
- (8) Set **RANGE** switch to **10 mW**.
- (9) Set power meter calibrator **POWER** switch to **10 mW**.
- (10) Set power meter calibrator **ZERO/TEST** switch to **ZERO** and, if necessary, adjust **ZERO** control for multimeter indication of ±1 mV dc.
- (11) Set power meter calibrator **ZERO/TEST** switch to **TEST**.
- (12) If TI contains A2R86 (fig. 1), adjust potentiometer for multimeter indication between 0.999 and 1.001 V dc and repeat (10) and (11) above. Return TI **RANGE** and power meter **CALIBRATOR** switch to **1 mW**. If necessary, readjust A2R6 (fig. 1) for TI meter indication between 0.99 and 1.01 mW (0.995 and 1.005 mW for model 432B) (R).
- (13) Repeat (1) through (12) above for optimum indications for **RANGE** switch positions **1 mW** and **10 mW**.

**NOTE**

If indications in (1) through (13) above are within specified limits, repeat **8 a** above. If indications are not within specified limits, continue with (14) below.

- (14) If applicable, set OPERATE/CALIBRATE SWITCH A2S1 (fig. 1) to **OPERATE**.

- (15) Set **RANGE** switch to **10 mW** and power meter calibrator **FUNCTION** switch to **SET**.
- (16) Disconnect multimeter from **TI RECORDER** output connector.
- (17) Connect multimeter (differentially) between A1TP5 and A1TP6 (fig. 3).

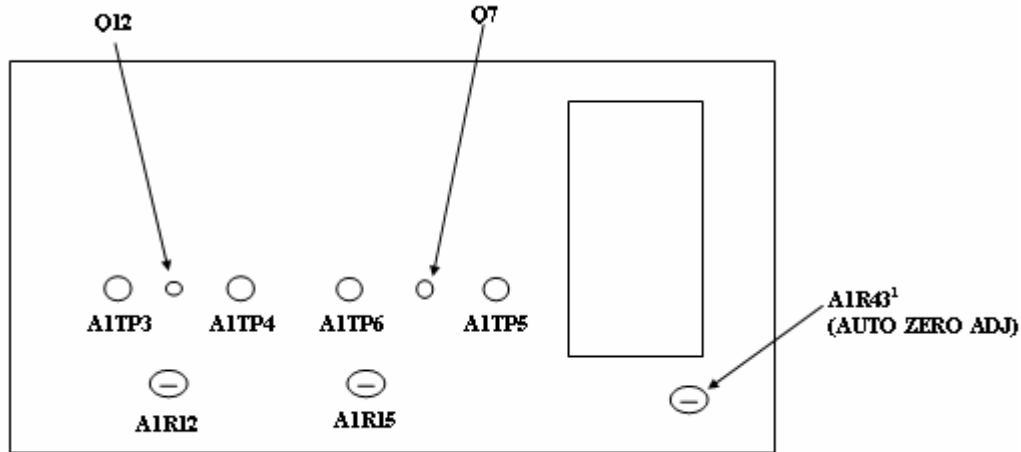

<sup>1</sup>NOT ON ALL 432A MODELS

Figure 3. Test instrument - right side view.

- (18) Adjust A1R12 (fig. 3) for multimeter indication of  $\pm 0.1$  mV dc (R).
- (19) Set power meter calibrator **FUNCTION** switch to **CHECK**. Multimeter will indicate  $\pm 0.4$  mV dc.
- (20) Set power meter calibrator **FUNCTION** switch to **SET**.
- (21) Connect multimeter (differentially) between A1TP3 and A1TP4 and adjust A1R15 (fig. 3) for multimeter indication of  $\pm 0.1$  mV dc (R).
- (22) Set power meter calibrator **FUNCTION** switch to **CHECK**. Multimeter will indicate  $\pm 0.4$  mV dc.

**NOTE**

If adjustments were made in (14) through (22) above, repeat **b** (1) through (13) above and, if applicable, set **OPERATE/CALIBRATE SWITCH A2S1** (fig. 1) to **CALIBRATE**. If TI indications in (14) through (22) are within specified limits, repeat **8 a** above.

**9. Calibration Factor Test**

**a. Performance Check**

- (1) Set power meter calibrator **ZERO/TEST** switch to **TEST** and **POWER (mW)** switch to **0.1 mW**.
- (2) Set **TI RANGE** switch to **0.1 mW (100  $\mu$ W for model 432B)** and **CALIBRATION FACTOR** switch to **88%**.

**TB 9-6625-1935-24**

(3) Adjust power meter calibrator **ZERO** control for multimeter indication between 0.998 and 1.002 V dc (0.999 and 1.001 V dc for model 432B).

(4) Set **CALIBRATION FACTOR** switch to positions listed in table 4. Multimeter will indicate within limits specified.

(5) Repeat (3) above.

**b. Adjustments.** No adjustments can be made.

Table 4. Calibration Factor Test

CALIBRATION FACTOR switch (%) settings	Multimeter indications (V)			
	Model 432A		Model 432B	
	Min	Max	Min	Max
<b>89</b>	0.979	0.999	0.984	0.994
<b>90</b>	0.968	0.988	0.973	0.983
<b>91</b>	0.957	0.977	0.962	0.972
<b>92</b>	0.947	0.967	0.952	0.962
<b>93</b>	0.936	0.956	0.941	0.951
<b>94</b>	0.925	0.945	0.930	0.940
<b>95</b>	0.916	0.936	0.921	0.931
<b>96</b>	0.906	0.926	0.911	0.921
<b>97</b>	0.897	0.917	0.902	0.912
<b>98</b>	0.887	0.907	0.892	0.902
<b>99</b>	0.879	0.899	0.884	0.894
<b>100</b>	0.870	0.890	0.875	0.885

**10. Meter Linearity Test**

**a. Performance Check**

(1) Set **RANGE** switch to **3 mW** (**10 mW** for model 432B).

(2) Set power meter calibrator **POWER (mW)** switch to **1**. TI meter will indicate between 0.97 and 1.03 mW (0.95 and 1.05 mW for model 432B).

(3) Set power meter calibrator **POWER (mW)** switch to **2**. TI meter will indicate between 1.97 and 2.03 mW (1.95 and 2.05 mW for model 432B).

(4) Set power meter calibrator **POWER (mW)** switch to **3**. TI meter will indicate between 2.97 and 3.03 mW (2.95 and 3.05 mW for model 432B).

**b. Adjustments.** No adjustments can be made.

**11. Zero Carryover Test**

**a. Performance Check**

(1) Deenergize and disconnect TI to power meter calibrator and multimeter. Connect thermistor mount to TI.

(2) If applicable, set OPERATE/CALIBRATE SWITCH A2S1 (fig. 1) to **OPERATE**.

(3) Energize TI and allow 10 minutes to warm-up and stabilize.



- (4) Set **RANGE** switch to **COARSE ZERO** and adjust **COARSE ZERO** screwdriver adjustment for a **0** indication on TI meter.
- (5) Set **RANGE** switch to **.01 mW (10 μW)** on model 432B).
- (6) Press **FINE ZERO** switch. If TI meter does not indicate **0 ±0.05 μW**, perform **b** below.
- (7) Set **RANGE** switch to each position (except **AUTO** on model 432B). If TI meter does not indicate within one-fourth minor division of **0** for model 432A, or does not indicate within specified limits in table 5 for model 432B, perform **b** below.

Table 5. Zero Carryover Test

RANGE switch settings	Meter indications	
	Min	Max
<b>100 μW</b>	-0.5 μW	+0.5 μW
<b>1 mW</b>	-0.005 mW	+0.005 mW
<b>10 mW</b>	-0.05 mW	+0.05 mW

**b. Adjustments**

- (1) Press **FINE ZERO** switch and adjust A1R43 AUTO ZERO ADJ (fig. 3) for a **0** indication. For model 432B, if TI meter cannot be adjusted to **0**, perform (2) through (8) below (R).

**NOTE**

A1R43AUTO ZERO ADJ (fig. 3) is not included on some 432A models.

- (2) Deenergize TI and remove front meter cover and side panels. Remove circuit board assemblies A1 and A2.
- (3) Reinstall meter with readout device exposed.

**CAUTION**

Assure meter is installed right-side-up and that connectors XM1 and XM2 are not reversed or shorted. If power is applied while meter is installed upside-down, meter will be damaged.

- (4) Short pins 10 and 12 of XA2 (fig. 4) together.

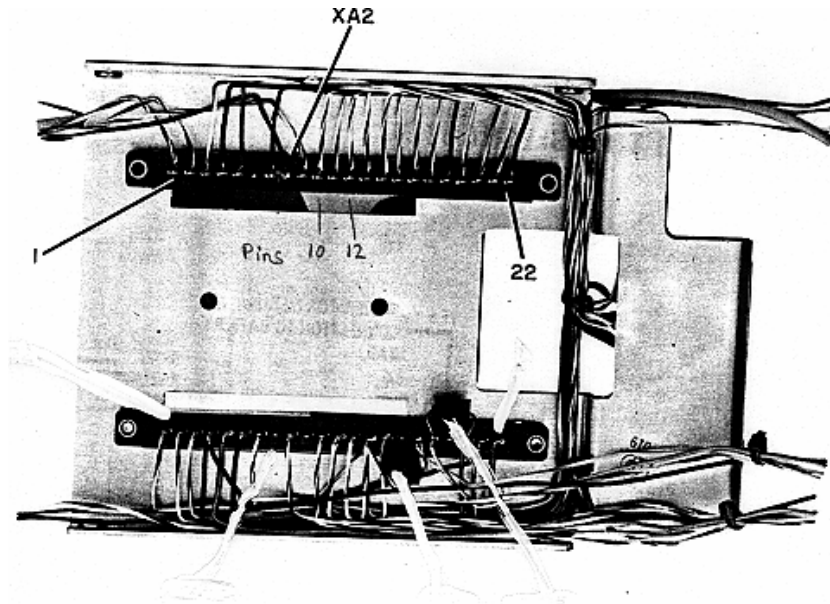

Figure 4. Bottom view - component locations.

- (5) Energize TI.

#### WARNING

HIGH VOLTAGE is present at digital panel meter face, connector XM1, and power supply transformer pins. DEATH ON CONTACT may result if personnel fail to observe safety precautions.

- (6) Using nonmetallic screwdriver, adjust potentiometer marked Z (upper right corner of TI panel meter face) for a 0 indication on TI meter (R).

- (7) Deenergize TI and reinstall circuit board assemblies A1/A2 and meter with meter cover. Remove short from pins 10 and 12 of XA2.

- (8) Energize TI and repeat 11 a above.

## 12. Final Procedure

- a. Deenergize and disconnect all equipment and reinstall covers which may have been removed from TI.

- b. Annotate and affix DA label/form in accordance with TB 750-25.

**SECTION IV  
CALIBRATION PROCESS  
WITHOUT POWER METER CALIBRATOR**

**13. Preliminary Instructions**

- a. The instructions outlined in paragraphs 12 and 13 are preparatory to the calibration process. Personnel should become familiar with the entire bulletin before beginning the calibration.
- b. Items of equipment used in this procedure are referenced within the text by common name as listed in table 2.
- c. Unless otherwise specified, verify the result of each test and, whenever the test requirement is not met, take corrective action before continuing the calibration. Adjustments required to calibrate the TI are included in this procedure. Additional maintenance information is contained in the manufacturer's manuals for this TI.
- d. Unless otherwise specified, all controls and control settings refer to the TI.

**14. Equipment Setup**

**WARNING**

HIGH VOLTAGE is used or exposed during the performance of this calibration. DEATH ON CONTACT may result if personnel fail to observe safety precautions. REDUCE OUTPUT(S) to minimum after each step within the performance check where applicable.

**NOTE**

The following procedures are oriented to model 432A (ME-441/U) power meter. The technique for calibrating model 432B is the same with the following exceptions. Model 432B has only four range switch settings, 10  $\mu$ W, 100  $\mu$ W, 1 mW and 10 mW. Omit checks for 0.03 and 0.3 mW ranges when calibrating model 432B.

- a. If necessary, mechanically zero model 432A (ME-441/U) meter as follows:
  - (1) Rotate mechanical adjustment screw clockwise until pointer is to left of **0** and moving up scale toward **0**. Stop when pointer is over **0** mark. If pointer overshoots, repeat the process.
  - (2) With pointer over **0**, turn adjustment screw approximately three degrees counterclockwise to free meter movement. If pointer moves off **0**, repeat adjustment.
- b. Connect TI to a 115 V ac source.

## 15. Meter Accuracy and Zero Carryover Test

### a. Performance Check

- (1) Position controls as listed in (a) through (c) below:
  - (a) **RANGE** switch to **COARSE ZERO**.
  - (b) **MOUNT RESISTANCE** switch to **200 Ω**.
  - (c) **CALIBRATION FACTOR** switch to **100 %**.
- (2) Connect thermistor mount to TI.
- (3) Energize TI and allow 10 minutes to warm-up and stabilize.
- (4) Adjust **COARSE ZERO** screwdriver adjustment for a **0** indication on TI meter.
- (5) Set **RANGE** switch to **.01 mW (10 μW** on model 432B).
- (6) Press **FINE ZERO** switch. If TI meter does not indicate within one-fourth minor division of 0 (zero) for model 432A, or does not indicate within specified limits in table 5, for model 432B, perform **b** (1) through (7) below.
- (7) Select a range and adjust **COARSE ZERO** control to indicate some convenient on-scale reading.
- (8) Connect multimeter (differentially) to **VRF** and **VCOMP** center conductors, using two adapters. Record multimeter indication as  $V_1$ .
- (9) Measure and record voltage between **VRF** center conductor and ground (outer conductor of BNC connector).
- (10) Measure and record voltage between **VCOMP** center conductor and ground (outer conductor).
- (11) Calculate power by substituting recorded indications in the following formula:

$$\frac{(V_1) (VCOMP + VRF)}{800}$$

- (12) If calculated power is not within  $\pm 1$  percent full-scale of indicated power for model 432A, or  $\pm 0.5$  percent full-scale for model 432B, perform **b** (8) below.
- (13) Set **RANGE** switch to as many positions as possible while adjusting the **COARSE ZERO** control to maintain a convenient on-scale indication and repeat (8) through (12) above.

### b. Adjustments

- (1) Press **FINE ZERO** pushbutton and adjust A1R43 AUTO ZERO ADJ (fig. 3) for a **0** indication. For model 432B, if TI meter cannot be adjusted to **0**, perform (2) through (9) below (R).

#### NOTE

A1R43 AUTO ZERO ADJ is not included on some 432A models.

(2) Deenergize TI and remove front meter cover and side panels. Remove circuit board assemblies A1 and A2.

(3) Reinstall meter with readout device exposed.

**CAUTION**

Assure meter is installed right-side-up and that connectors XM1 and XM2 are not reversed or shorted. If power is applied while meter is installed upside-down, meter will be damaged.

(4) Short pins 10 and 12 of XA2 (fig. 4) together.

(5) Energize TI.

**WARNING**

HIGH VOLTAGE is present at digital panel meter face, connector XM1, and power supply transformer pins. DEATH ON CONTACT may result if personnel fail to observe safety precautions.

(6) Using nonmetallic screwdriver, adjust potentiometer marked Z (upper right corner of TI panel meter face) for a **0** indication on TI meter.

(7) Deenergize TI and reinstall circuit board assemblies A1/A2 and meter with meter cover. Remove short from pins 10 and 12 of XA2 (fig. 4).

(8) Energize TI and repeat **a** above.

(9) Adjust A2R6 (fig. 1) to obtain a calculated power within the tolerance stated in **a** (12) above (R).

**16. Recorder Output Test**

**a. Performance Check**

(1) Connect multimeter to TI **RECORDER** output connector, using adapter.

(2) Set **RANGE** switch as necessary and adjust **COARSE ZERO** control for an indication of **1** on TI meter **0 to 1** scale. If multimeter does not indicate between 0.995 and 1.005 V dc, perform **b** below (R).

**b. Adjustment.** Adjust A2R74 (fig. 1) for a multimeter indication between 0.995 and 1.005 V dc (R).

**17. Calibration Factor Test**

**a. Performance Check**

(1) Set **CALIBRATION FACTOR** switch to **88%**.

(2) Adjust **COARSE ZERO** control for a 1.000 V dc indication on multimeter.

(3) Set **CALIBRATION FACTOR** switch to positions listed in table 4. Multimeter will indicate within limits specified for each position.

**TB 9-6625-1935-24**

- b. Adjustments.** No adjustments can be made.

**18. Final Procedure**

- a.** Deenergize and disconnect all equipment and reinstall TI protective cover.
- b.** Annotate and affix DA label/form in accordance with TB 750-25.

By Order of the Secretary of the Army:

GEORGE W. CASEY, JR.  
*General, United States Army*  
*Chief of Staff*

Official:

  
JOYCE E. MORROW  
*Administrative Assistant to the*  
*Secretary of the Army*

0712101

Distribution:

To be distributed in accordance with the initial distribution number (IDN) 342150,  
requirements for calibration procedure TB 9-6625-1935-24.





### Instructions for Submitting an Electronic 2028

The following format must be used if submitting an electronic 2028. The subject line must be exactly the same and all fields must be included; however, only the following fields are mandatory: 1, 3, 4, 5, 6, 7, 8, 9, 10, 13, 15, 16, 17, and 27.

From: "Whomever" [whomever@redstone.army.mil](mailto:whomever@redstone.army.mil)  
To: <2028@redstone.army.mil

Subject: DA Form 2028

1. **From:** Joe Smith
2. **Unit:** home
3. **Address:** 4300 Park
4. **City:** Hometown
5. **St:** MO
6. **Zip:** 77777
7. **Date Sent:** 19-OCT-93
8. **Pub no:** 55-2840-229-23
9. **Pub Title:** TM
10. **Publication Date:** 04-JUL-85
11. **Change Number:** 7
12. **Submitter Rank:** MSG
13. **Submitter FName:** Joe
14. **Submitter MName:** T
15. **Submitter LName:** Smith
16. **Submitter Phone:** 123-123-1234
17. **Problem:** 1
18. **Page:** 2
19. **Paragraph:** 3
20. **Line:** 4
21. **NSN:** 5
22. **Reference:** 6
23. **Figure:** 7
24. **Table:** 8
25. **Item:** 9
26. **Total:** 123
27. **Text**

This is the text for the problem below line 27.





